

First measurements with the AUGER fluorescence detector data acquisition system

H. Gemmeke, M. Kleifges, A. Kopmann, N. Kunka, A. Menshikov, and D. Tcherniakhovski

Forschungszentrum Karlsruhe, HPE, Postfach 3640, 76021 Karlsruhe

Abstract. The international Pierre Auger collaboration will investigate the highest energy cosmic rays ($E > 10^{19}$ eV) with respect to the primary particle origin, the energy spectrum and the chemical composition. The experiment will be built up as hybrid design in the Pampa Amarilla in the province of Mendoza, Argentina. It consists of 1600 water Cerenkov stations to measure the lateral shower distribution and 4 fluorescence stations with a total of 30 telescopes (Schmidt cameras) to view the longitudinal shower development.

During summer 2000 the collaboration has started to install an engineering array consisting of 40 tanks and 2 telescopes. We report on the development and test of the digital front-end electronics, the multi-level trigger system and the DAQ. First results of the electronics and trigger performance gained with the engineering array are presented.

1 Introduction

Recent experiments (Takeda et al. , 1998; Cronin , 1999) have shown that cosmic ray particles with energies above 10^{20} eV hit the total atmosphere roughly once per second. This very low rate makes it difficult to measure the primary particles properties with sufficient statistical accuracy. Therefore the nature of the primary cosmic particle, the mechanism of its acceleration and the locations of particle sources are still unknown. Much theoretical work has been done, but no generally approved working model exists to describe all observations.

So far, around 10 to 20 events have been recorded (Nagano and Watson , 2000). The international Pierre Auger collaboration aims to provide more experimental results by measuring the energy spectrum, the arrival direction and the iso-

tope composition of ultra-high energetic primary particles above 10^{19} eV. The very low integrated particle flux of only 1 event / $\text{km}^2/100$ years ($E > 5 \times 10^{19}$ eV) requires a large acceptance of $7000 \text{ km}^2\text{sr}$ for the experiment to accumulate enough events.

The Pierre Auger Observatory will consist of the Cerenkov Surface Detector (SD) array with 1600 equally distributed water tanks and the Fluorescence Detector (FD) with 30 telescopes which watch the night sky above the experimental area to an angle of elevation up to 31° . The advantage of this hybrid design is that both the lateral and the longitudinal development of the cosmic ray shower can be observed simultaneously. Thus many parameters of each event are measured in parallel and the angular and energy resolution of each subsystem is improved.

At present, the collaboration builds up the engineering array — a prototype system of 40 SD tanks and 2 FD telescopes. All of the prototype tanks are already deployed and filled with water, the required electronics is currently being installed. At end of May 2001 one FD telescope is commissioned and it has already recorded data. The installation of the second telescope is scheduled to be completed in July 2001. In the following chapters we report on the electronic system of the FD prototype, details of the overall detector system are published elsewhere (Auger Contribution to ICRC , 2001).

2 System Concept

Fluorescence light from a cosmic ray shower enters the aperture system of the FD telescopes, is reflected by a spherical mirror (radius of curvature $R = 3.4$ m) and is detected by a camera located in the focus of the Schmidt optics as shown in fig. 1. The camera consists of 440 hexagonal photomultipliers (PMT), which are arranged in a matrix of 20 columns by 22 rows.

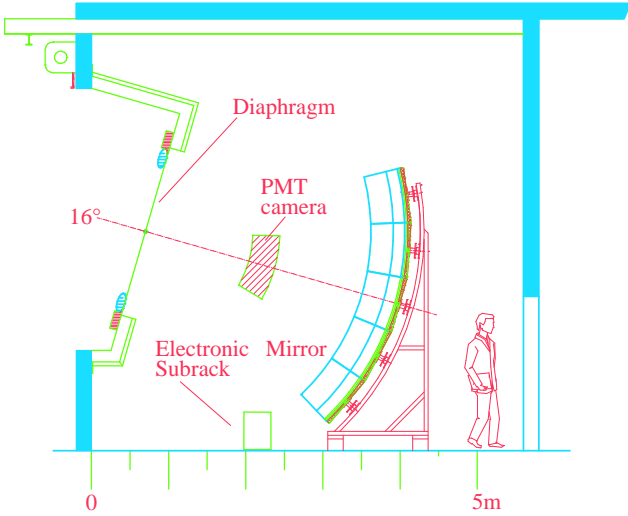

Fig. 1. Schematic view of the telescope with aperture, mirror, camera and electronic subrack.

Figure 2 shows the block diagram of the front-end electronics and DAQ system for 6 telescopes located in the same building. The system consist of:

- the cameras with the PMTs,
- the front-end electronic subrack with the trigger boards,
- a Mirror PC per telescope for the higher level triggers and
- the Eye PC to collect all data and transfer it to the Auger Central Data Acquisition System (CDAS).

All parts are synchronized with a GPS-clock. Its signals are distributed through the Clock & Control Board (CCB).

The main tasks of the telescope electronics system are to shape the PMT signals, digitise and store them, compare the signals with the average background level, generate a trigger based on the camera image and initiate the readout of the stored data. In order to reduce the huge amount of data, we have implemented a 3-level trigger system as shown in table 1. The 1st and 2nd level are realized in FPGA logic by the First Level Trigger (FLT) and Second Level Trigger (SLT) boards, the 3rd level is implemented as a software trigger.

Table 1. Performance of trigger levels

Level	reduction by	rate [Hz]
Pure data	no	10^6 samples
1. Level	threshold on sliding average	200 per pixel
2. Level	4-fold geometrical tracks	0.2 per mirror
3. Level	space-time correlation, # of pixels	$\ll 0.01$ per FD

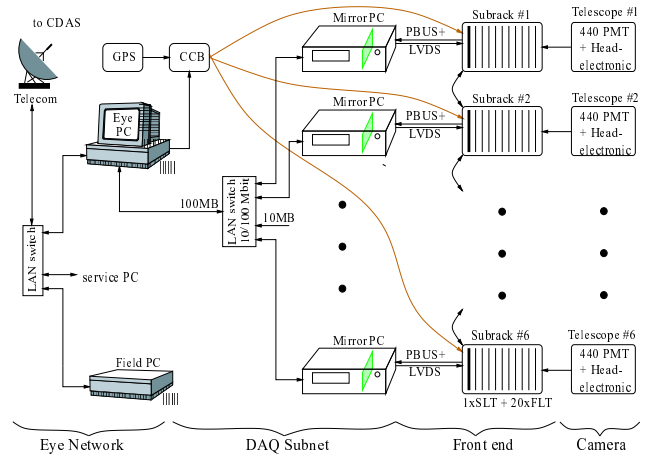

Fig. 2. Schematic of the electronics and DAQ of a FD station: camera, front-end subrack, Mirror PC and Eye PC.

As the system is designed for remote operation, we have to provide good test facilities. High reliability, mechanical robustness and low power consumption are required to achieve the planned 20 year live time.

3 First Level Trigger

The 20 First Level Trigger (FLT) boards are the heart of the digital front end electronics. Each board processes the signals of one camera column, i.e. it contains 22 input channels (one per camera row) and — in addition — two summing channels, which are the analog sum of the odd and even channel numbers at a lower gain, respectively. Each board gets its input signal from the attached Analog Board, which is a front-end board developed at INFN Milan, Pavia and Torino and contains differential line receivers, filters and variable gain amplifier for each PMT pixel (Argiro et al. , 2000).

All functions of the FLT are implemented in FPGA logic for high flexibility and cost-effectiveness. Instead of using a single FPGA chip, functions common to all 24 channels are shared between 4 'slave FPGAs' (Altera Flex 10K50) — each handling 6 input channels. More general functions of the board like the data exchange with the Mirror PC and the SLT or the interface to the Analog Board are implemented in a separate 'controller FPGA' (Altera Flex 10K100). This distribution of the functions among 5 FPGAs is the cheapest solution and still leaves resources for future add-on functions.

Each slave FPGA controls the synchronous sampling of 6 analog signals with a rate of 10 MHz and 12-bit resolution. The ADC values are stored every 100 ns in conventional $32K \times 16$ bit SRAM together with a 4-bit control information. The address space of each RAM is divided into 32 pages of 1024 words. Each page works as a circular buffer memory to hold the ADC values of the last $100\mu s$. In case of a trigger all FLT switch synchronously to new page address

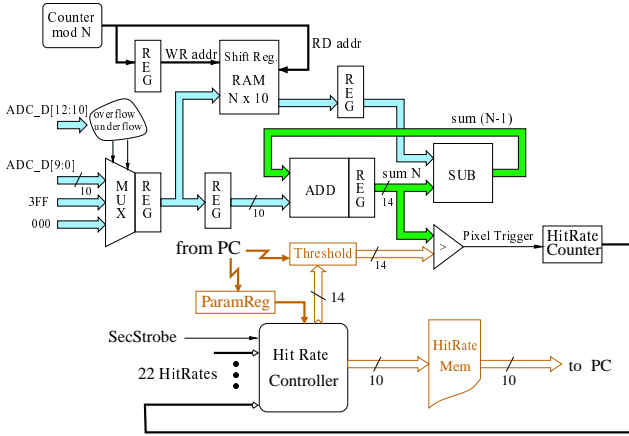

Fig. 3. Scheme for calculating the sliding sum, generation of the pixel trigger and regulation of the hit rate as implemented in the FLT slave FPGA.

and use it to store the data. The system continuously writes into the new circular buffer while the triggered event data is readout from the previous memory page without dead time.

The slave FPGA is also responsible for the first trigger stage. While the ADC values are continuously written to memory the sliding sum of the last N samples is calculated as shown in fig. 3. The default value for N is 10, it can be changed in the range $5 \leq N \leq 16$. A pixel is marked as triggered, whenever the sliding sum exceeds an adjustable threshold. The pixel trigger is valid during the overlap coincidence time (default value $20\mu\text{s}$).

The improvement achieved by applying the threshold to the sliding sum is illustrated in fig. 4. It compares the distribution of the ADC values as measured with night sky signals (dashed) with the distribution of the sliding sum over 16 values (solid) of the same data set. The width of the signal distribution is drastically reduced by a factor of 2.8 thus improving the signal-to-noise ratio. The theoretical possible improvement by a factor $\sqrt{16}$ is not achieved as adjacent ADC values are not independent due to the analog filter.

The random trigger rate of the second trigger stage is highly dependent of the individual pixels trigger rate. Therefore this hit rate is continuously measured during a maximal 32 s long time interval. It serves as input variable for the automatic adjustment of the threshold in a closed loop according to fig. 3. Depending on the comparison of the measured rate with the demand rate the threshold is changed in appropriately. In this way changing background light intensities are compensated and the random coincidence rate of the SLT is kept constant.

4 Second Level Trigger (SLT)

The tasks of the SLT are shared between two FPGAs - the trigger FPGA (T-FPGA) and the controller FPGA (C-FPGA). They are both connected to a dual-port RAM, which works

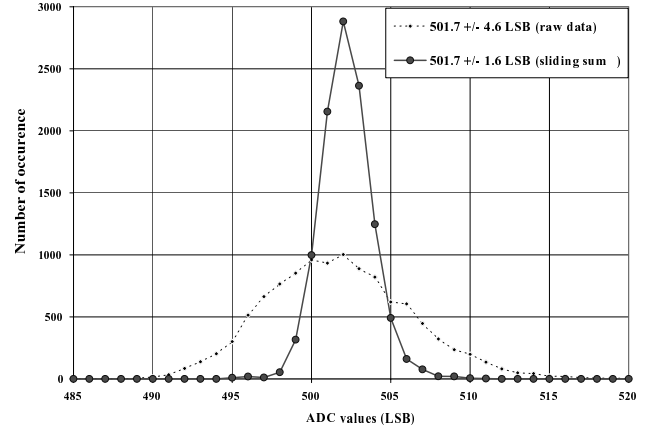

Fig. 4. Comparison of ADC data distribution measured with night sky background as pure data (dashed) and with effect of sliding sum (solid line).

as a circular memory to store the pixel trigger information. The C-FPGA provides the functions to access this memory and the 20 FLT boards from the Mirror PC. It holds registers to store the time stamp and status information for each memory page.

The T-FPGA reads every 50 ns the pixel trigger into a pipeline of 5 stages. Each stage holds the pixels of one column, i.e. the pipeline holds the image of a 22×5 submatrix of the camera. A pattern algorithm searches with a coincidence logic for tracks of fluorescence light inside this submatrix while the image is shifted column by column over the full camera. Straight tracks require a coincidence of 4 pixels out of a 5-fold pixel pattern shown in fig. 5. Depending on the shape and the orientation in space, 108 different pattern classes have to be distinguished. If the coincidence condition is fulfilled for any of the pattern classes, the recording of ADC data is continued in the next free circular buffer and the Mirror PC is informed.

5 DAQ and Third Level Trigger

Interrupts of the front-end are handled by the Mirror PC associated to each telescope. It accesses the front end via the commercially available microEnable board (Silicon Software, 1998) — a PCI plug-in card containing FPGA logic and fast SRAMs used as temporary memory during readout.

The DAQ systems provides a third trigger level implemented in software. The readout of the pixel information from the SLT allows to identify the involved pixels in an event and their trigger times. A simple cut on the number of involved pixels (track length) or the quality of the space-time linearity reduces random coincidences and muon background (see below).

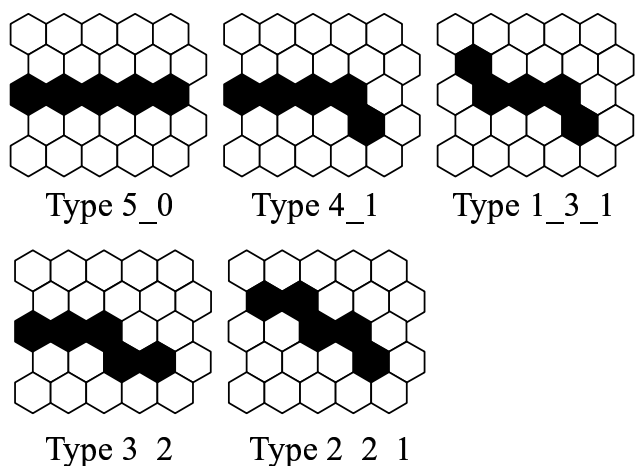

Fig. 5. Basic topological types of pattern used for pattern recognition algorithm of the SLT logic.

6 Results and Conclusion

Before the camera and electronics system was shipped to Argentina it had to undergo an integration test carried out in Rome in March 2001. We verified the full readout path from the PMT, through the analog electronic, the FLT board and the computer system. With light pulses from external LED light sources and signals from a pattern generator integrated on the front-end electronics we verified the function of the complex trigger system — especially the pattern recognition algorithm of the SLT. The electric properties of the system are a high linearity over the full dynamic range of 15-bit, a cross talk between channels of less than 6×10^{-4} and the electronic noise of about $\sigma^2 = 4.6(\text{LSB})^2$ at a PMT gain of 50 000.

The extensive tests in Rome reduced the commissioning time in Malargue significantly. Within 2 weeks the camera

was assembled and the front-end electronic installed. First we measured the electronic noise and found a value similar to the result of Rome. The fluctuations caused by DC night sky light were found to be 3 to 4 times larger than the electronic induced noise.

During two nights (22.–24.May) the telescope recorded for the first time night sky data with a preliminary DAQ program. The majority of events were short pulses simultaneously in adjacent pixels caused by muons traversing the PMTs. However, 6 events were found with the specific properties expected for cosmic ray showers. The triggered pixels follow a linear space-time correlation, the transition time per pixel varies between 300 ns and 1 μ s. A detailed analysis of this candidate events is in progress. However, an estimate of the shower energy will hardly be possible due to missing calibration data and information of the atmospheric attenuation length.

We have scheduled four further measuring campaigns during new moon periods till November 2001. The second prototype telescope should allow us to find events across mirror boundaries and in correlation with SD prototype. We are confident that the FD prototype will reach its expected performance.

References

- M. Takeda et.al., Phys. Rev. Lett 81, 1163 (1998)
- James W.Cronin, Rev. Mod. Phys. 71, No. 2 (1999) 165
- M. Nagano and A.A. Watson, Rev. Mod. Phys. 72, (2000) 689
- See other contributions to this ICRC Conference (2001) and the upcoming Rev. in Journal of Physics G
- S. Argiro et al., The analog Signal Processor of the Auger Fluorescence Detector Prototype, presented at the Elba meeting on Advanced Detectors 2000, to be published in NIM
- Silicon Software GmbH, The microEnable FPGA-Coprocessor at <http://www.silicon-software.com>.